

Surrey Area of NAFAS

presents

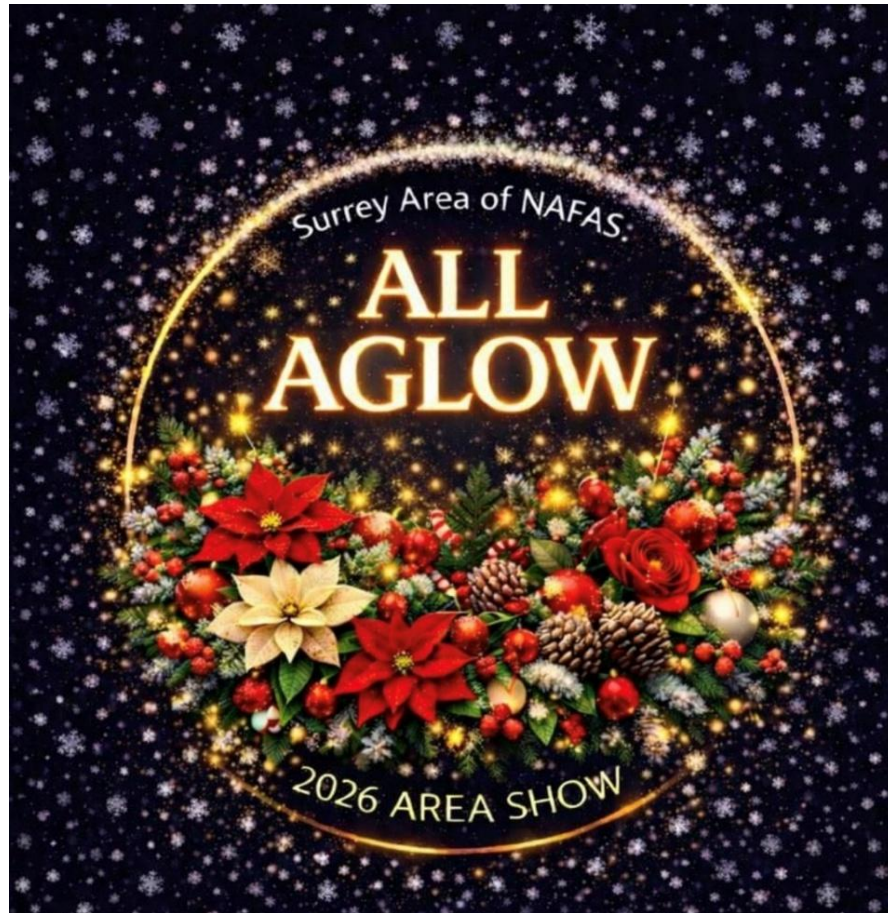

27 and 28 November 2026

at

**The Dell Centre, St Giles Church, Park Lane
Ashted KT21 1EJ**

Supporting Stepping Stones

Show Committee

Chairman
Secretary
Treasurer
Staging

Competitors / Stewards
Catering
Social Media
Trophies / Raffle

Charity Stall

Lynis Williams
Linda Mumford
Tony Williams
Margaret Trepant
Sune Larsen-Walsh
Sue Drinkwater
Di Henderson
Sune Larsen-Walsh
Angela Norman

Rachel Sherwin

Judges

Michael Bowyer
Martina Coleman

Programme of Events

Friday 27 November

Staging
Judging

8.00am – 12 noon
2.00pm – 6.00pm

Saturday 28 November

Show Open Day Admission £5
Prize Giving
Breakdown

10.00am – 4.00pm
3.30pm
4.00pm

Tickets will be available on the door.

Floral Art Schedule

All classes in this schedule are to be regarded as exhibits.

Class 1 Panto Time

An Inter-Society Class

Space allowed: 90cm width x 90cm depth x height optional. Staged on the mid oak floor with a bright red curtain background. Pantomime to be named. Viewed and judged from the front. 1 or 2 members nominated by their Club may stage this exhibit.

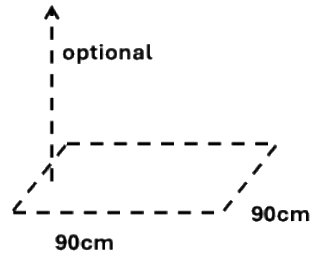

Class 2 Silent Night

A Landscape exhibit

Space allowed: 85cm width x 75cm depth x height optional. Staged on tabling with green drape against off-white background. Viewed and judged from the front.

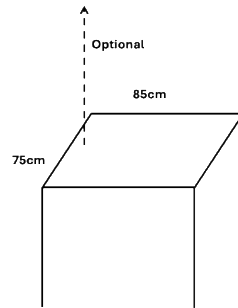

Class 3 Seasonal Sculpture

Space allowed: 80cm width x 80cm depth x height optional. Staged on light oak floor with off-white background. Viewed and judged from the front.

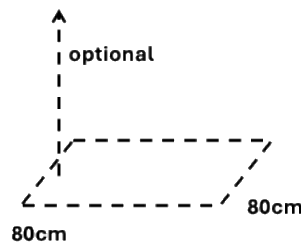

Class 4 Cones and Candles

Novice Class

Space allowed: 70cm width x 60cm depth x 90cm height. Staged on tabling with green drape against green backing. Viewed and judged from the front.

This class is open to members who have not won a first, second or third award at an Area or National Show. Demonstrators, teachers and judges are excluded.

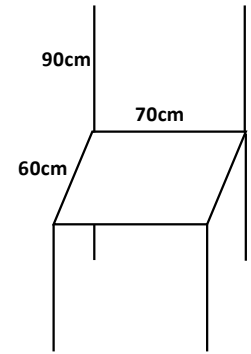

Class 5 All Aglow

Space allowed: 85cm width x 75cm depth x height 120cm. Staged on tabling with green drape against green backing. Viewed and judged from the front.

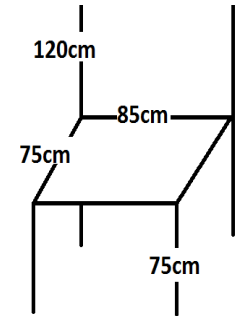

Class 6 Festive Welcome

A seasonal door hanging

Space allowed: 60cm width x 20cm depth x 80cm height. Must be brought ready done with a hanging loop, to hang against an off-white door background. Viewed and judged from the front.

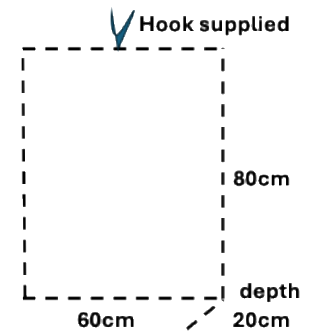

Class 7 On Thin Ice

A horizontal layered design

Space allowed: 90cm width x 40cm depth x height optional. Staged on a pale grey painted solid block 60cm width x 40cm depth x 40cm height, placed on a table with green drape and green backing. Viewed and judged from the front.

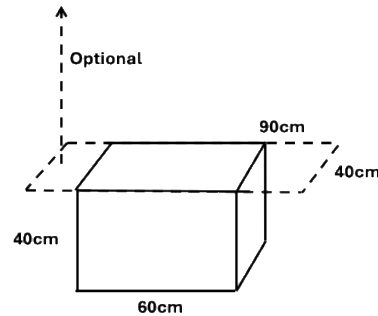

Class 10 Oh, Christmas Tree

A Petite exhibit

Space allowed: 25cm width x 25cm depth x 37cm height. Staged on tabling with green drape against pale green backing. May be brought ready done. Viewed and judged from the front.

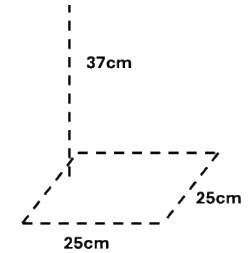

Class 8 Good Things Come in Small Packages

A miniature exhibit

Space allowed: 10cm width x 10cm depth x 15cm height. Staged on a pale grey painted table 120cm high. May be brought ready done. Viewed and judged from the front.

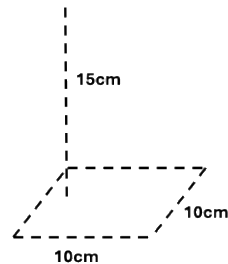

Class 9 Party Time

Space allowed: 80cm width x 80cm depth x height optional. Staged on a pale grey painted plinth 20cm width x 20cm depth x 120 height. No floor placements are allowed and plant material must be at least 20cm above the floor. Viewed and judged all round.

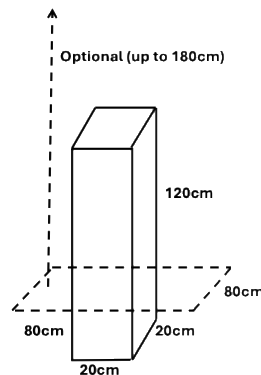

This schedule has been written to be in accordance with the NAFAS Competitions Manual Fourth Edition (2023). If you have any queries or questions, or you would like clarification of any points please contact: margaret.trepant@gmail.com or chairmansurreynafas@gmail.com

Staging Regulations

1. Only competitors and officials will be allowed in the hall during staging.
2. Staging will be on Friday 27 November 8am – 12 noon. All competitors must vacate the building by 12 noon.
3. Judging will be on Friday 27 November 2.00 – 6.00pm.
4. Dismantling will be on Saturday 28 November 4.00pm – 4.30pm.
5. All measurements in the staging description are **approximate** and the **diagrams are not to scale**. Tables are about 75cm high.
6. Artificial plant material may be used in Classes 1, 6 and 9. Natural plant material must predominate in all exhibits.
7. Aerosol sprays and glue guns may not be brought into or used anywhere on the premises, inside or outside. Nothing may be attached to the Area staging in any class.
8. Please remember that the venue is a Church Hall and respect the furnishings, carpet etc. The walls are painted off-white and the floor is medium grey carpet or light wood. For more information and to see the venue website please visit <https://sgsgashtead.org.uk/venue-hire>.

Regulations

1. Only members of Clubs and Societies affiliated to the Surrey Area of NAFAS may compete. Members of Surrey Designer Clubs are encouraged to compete. However, those who are members of both a Design Club and a local Surrey Club may only compete on behalf of their local Flower Club. This regulation does not apply to Class 1. The Designer Clubs are Focus 2000, Southern Demonstrators and Winkworth Floral Designers.
2. Entries must be received between Monday 28 September and Saturday 12 October 2026. An individual competitor may enter up to three classes.
3. Enter online using the instructions on the entry form.
4. Any class oversubscribed will be balloted.
5. All exhibits will be judged in accordance with this schedule and the NAFAS Competitions Manual Fourth Edition (2023). The Judges' decision is final.
6. An exhibit must be staged within the space allowed. It must be the competitor's own work and not previously exhibited.
7. Exhibits must be assembled at the venue. Exceptions are Classes 8 and 10 which may be brought ready assembled and 6 which **must** be brought ready to hang. The competitor is expected to use the staging time to complete their exhibit but any items requiring time for their preparation (pre-done work) may be used but must not predominate.
8. All exhibits and competitor's property will be at the risk of the competitor. Neither the Area nor the Owners of The Dell Centre, or any part of them, can accept any liability whatsoever for any loss or damage.
9. The Surrey Area reserves the right to use photographs of any exhibit for any purpose.
10. Class 1 will not be included for consideration in the award for Best Individual Exhibit in Show.

Floral Art Awards

Best in Show	Surrey Floral Decoration Society Silver Salver
Runner-Up to Best in Show	Flowers for Florists Crystal Vase
Highest Number of Individual Points	Morecombe White Silver Casket & RHS Banksian Medal
Highest Number of Club Points	Mary Lyons Silver Challenge Cup
Judges' Choice	Halcyon Days Box
Best Use of Colour	Gwen Mason Trophy
Most Innovative Exhibit	Dallas Taylor Trophy
Most Beautiful Flowers	Joan Cooper Challenge Trophy
Best Use of Texture	Sue Slark Trophy
Most Elegant Exhibit	Beryl Went Trophy
Popular Choice	Esher Trophy
Class 1	Surrey Trophy
Class 2	Joan Newlyn Trophy
Class 3	Lady Hulme Williams Trophy
Class 4	Barbara Newell Trophy
Class 5	C Gordon Medlen Trophy
Class 6	H G Day Trophy
Class 7	Mark Kielbig Trophy
Class 8	Ashtead Trophy
Class 9	Phyllis Allpass Trophy
Class 10	Connie Bickle Trophy

The Surrey Area of NAFAS and the Show Committee would like to thank the management of The Dell Centre for allowing us to stage the 2026 Area Show in the venue.

Message from the Show Chairman...

Thank you for taking time to read this festive schedule. The Area Show team do hope you will be displaying your skills and taking part in this exciting Surrey Area Biennial Show.

We are pleased to be back at the Dell Centre which suited us so well last time. Not only do we admire the wonderful, creative designs of our fellow Surrey members but we get the chance to meet each other from all sides of our county. This year we will be offering refreshments again but, as it is winter, homemade soup is on offer. We have ordered extra Guinness Cake!

Our Charity this year is 'Stepping Stones DS'. This charity helps young people aged 0 to 25 with Downs Syndrome. The charity also offers support for the families of these young people. I do hope you will bake cakes to sell on our charity cake stall and also buy cakes to take home. Please label each cake with the ingredients.

I am deeply indebted to all the members of our Area Show team who have worked hard to put this show together.

Our team look forward to welcoming you on the staging day and offering you every support to showcase your talents. There is a class for everyone. We look forward to receiving your entries.

Best wishes and Good Luck

Lynis

Surrey Area Show Chairman